

REV.	DESCRIPTION	DATE	DWN	APVD
1	PRELIMINARY	17JUL09	JC	BC

MATERIAL:

- HOUSING-DSM STANYL TE250F6 (NYLON-46)  
HEAT DEFLECTION TEMP.290°  
BLACK COLOR, UL94V-0
  - CONTACTS-0.35mm THICK PHOS-BRONZE PLATED  
WITH HARD GOLD AND GOLD FLASH IN  
SOLDER AREA.
  - SHIELD-0.25mm THICK COPPER ALLOY,  
PLATED WITH NICKEL.
- CAVITY CONFIRMS TO FCC RULES AND REGULATIONS  
PART 68,SUBPART F.

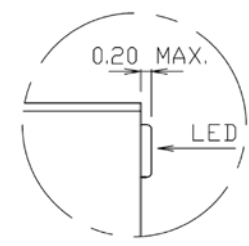
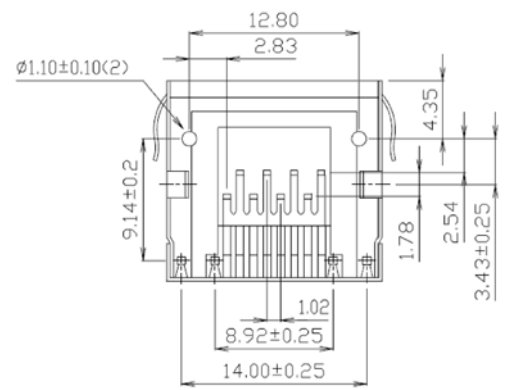
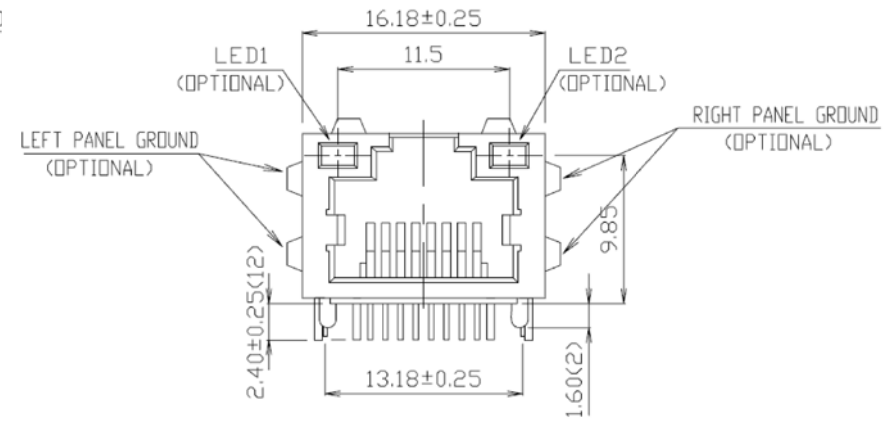
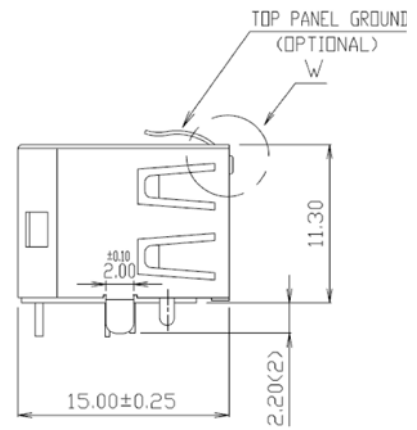
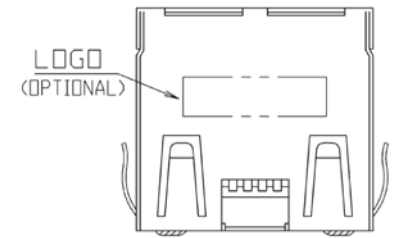

DETAIL W

PART NUMBER: 962107

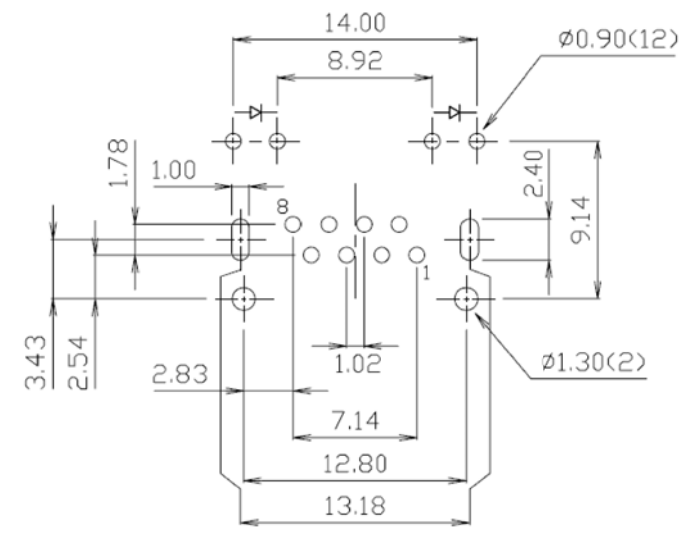

PCB LAYOUT  
Ref.

TOLERANCES UNLESS OTHERWISE SPECIFIED:		DWN	17JUL2009	<b>HAOGUO XING YE SHARE CO.,LTD.</b>	
0 PLC	± -	CHK	17JUL2009		
1 PLC	± 0.25	MARKS_CHEN		NAME	
2 PLC	± 0.13	APVD	17JUL2009		
3 PLC	± 0.05	BEST_CHANG		RJ45 RECEPTACLE CONNECTOR	
4 PLC	± -	PRODUCT SPEC			
ANGLES	± 3°	APPLICATION SPEC		SIZE	DRAWING NO
MATERIAL SEE NOTE		WEIGHT		A3	-
FINISH SEE NOTE		DIMENSIONS:		CUSTOMER DRAWING	SCALE
PROJECTION		MM		SHEET	1 OF 1
				REV	1