

REV.	DESCRIPTION	DATE	DWN	APVD
1	PRELIMINARY	01OCT09	JC	BC

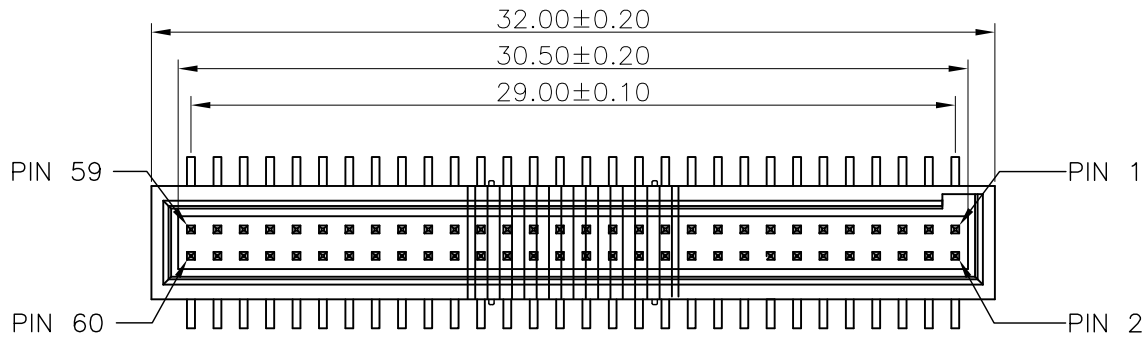

LTR	Part Name	Material	Description	QTY
1	Housing	NY-6T UL94V-0 BLACK	260°C for 10 Seconds . Initial : 1000M Ohms Min. After Test : 500M Ohms Min.	1
2	Contact	Brass C2700	Current Rating : 0.75A Initial : 20m Ohms Max. After Test : 40m Ohms Max.	60
3	Mylar	Polyimide Tape	250°C-SHORT TERM	1

Normal Force : 450 Grams Average .  
Temperature Rating : -40°C ~ +105°C .  
Dielectric Withstanding Voltage : 500V AC/Min

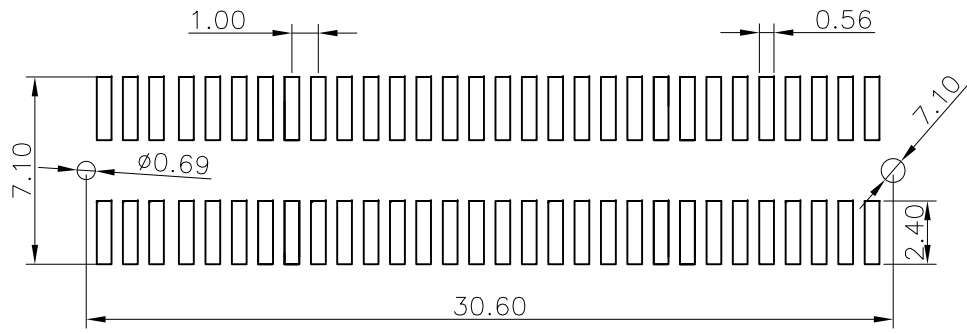
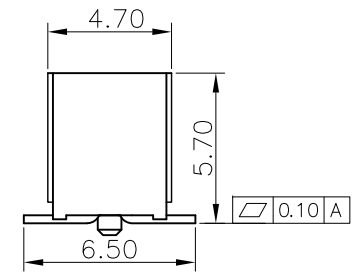
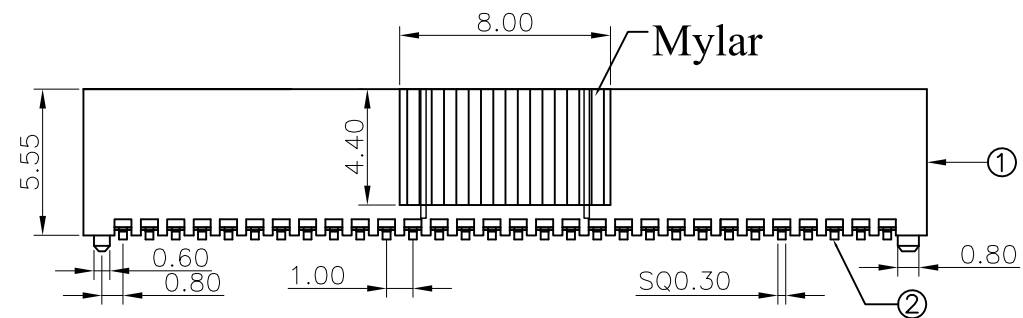

**P.C.B LAYOUT**

GOLD FLASH	J04-0100-01
MIN. GOLD THICKNESS	PART NUMBER

TOLERANCES UNLESS OTHERWISE SPECIFIED:	DWN JOHN_CHANG 01OCT2009	<b>HAOGUO XING YE SHARE CO.,LTD.</b>	
0 PLC ± -	CHK MARKS_CHEN 01OCT2009		
1 PLC ± 0.3	APVD BEST_CHANG 01OCT2009	NAME	
2 PLC ± 0.15	PRODUCT SPEC	PH1.0 Box Header Dual Row ,SMT	
3 PLC ± 0.1	APPLICATION SPEC	SIZE	DRAWING NO
4 PLC ± -	FINISH SEE NOTE	A3	J04-0100
ANGLES ± 3'	PROJECTION	WEIGHT	RESTRICTED TO
		- GRAMS	-
		DIMENSIONS: MM	CUSTOMER DRAWING
		SCALE	SHEET 1 OF 1
			REV 1